

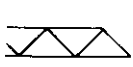





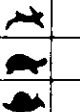

**KÖNIG**  
**Schnellmontage-Kran**

**K 16F**

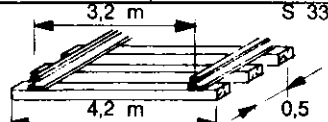
nach DIN 15018

	90°				30°			
	m	kg	m	kg	m	kg	m	kg
20 m	20	750	11,51	1500	17,5	750	10,18	1500
	40 m/min — 750 kg				7,7 KW			
	10 m/min — 1500 kg				3 KW			
	30 m/min	0,75 KW				 380 V Gesamtanschlußwert 13,0 KW		
	25 m/min	2 x 1,5 KW						
	0,5 + 1 u/min	0,95 + 1,5 KW						

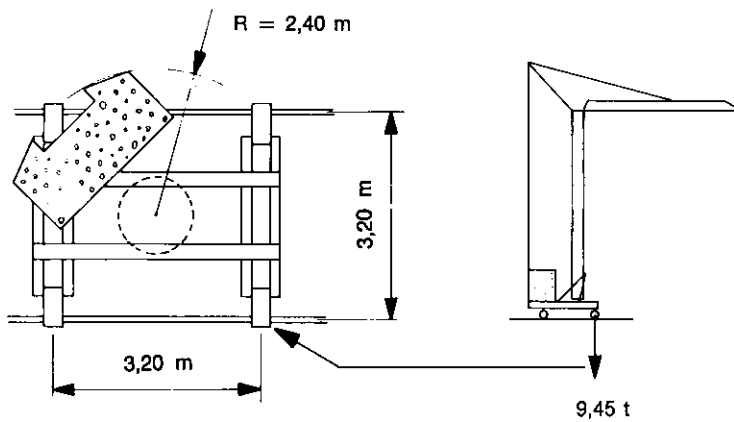

... besser gleich KÖNIG-KRANE

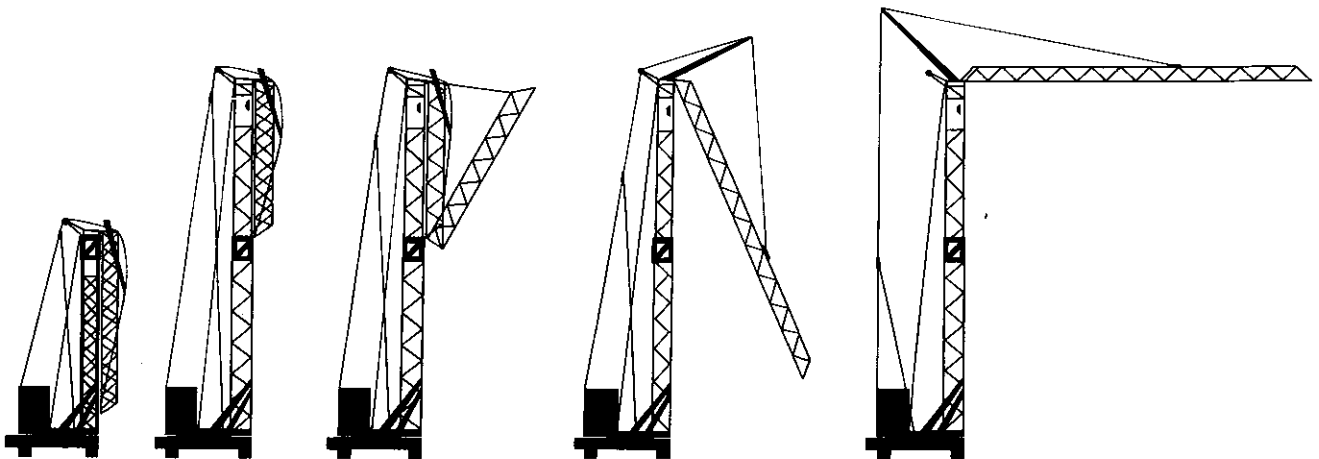

Wilh. König Baumaschinen-Stahlbau-GmbH - Werk I 5020 Frechen  
Werk II 5464 Asbach/Ww.

König-Baumaschinen-Vertrieb GmbH — 5464 Asbach/Ww. — Telefon (02683) Sa.-Nr. 4436 — Telex 0863712

Ihr Fachhändler berät Sie gern: